

Hopper system BBR

Characteristics

The large hopper volume of the hopper of type BBR prolongs the manual refilling cycles considerably and increases the efficiency of the entire system. Ideally, it is used for

the storage and dosed provision of light, large-volume parts. The specially shaped bulk hopper reduces the possibility of parts with unfavourable geometric forms getting

stuck, i.e. so-called „bridge-building“ is prevented.

A quick-emptying flap enables fast type changes.

Structure

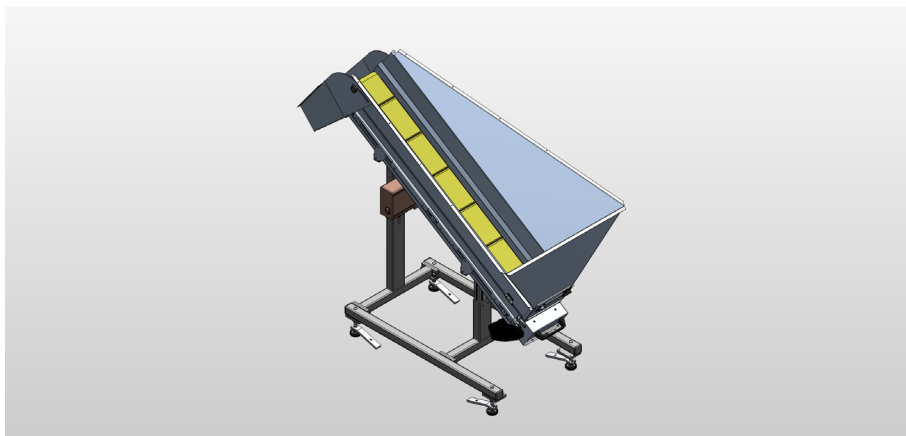

Colour scheme of the individual components:

- Motor
- Hopper control
- Conveyor belt

Technical data

Device type	BBR45	BBR70	BBR150	BBR250	BBR350
Material bulk hopper and chute	Stainless Steel	Stainless Steel	Stainless Steel	Stainless Steel	Stainless Steel
max. filling volume [l]	45	70	150	250	350
max. filling weight [kg]	75	75	75	75	75
Protection class in accordance with DIN EN 60529	IP 54	IP 54	IP 54	IP 54	IP 54
Article no.	VArt000684	VArt000654	VArt000656	VArt000657	VArt000655

Dimensions

Device type	Dimensions [mm]						Positioning angle A
	Outlet height H1 (approx.)	Filling height H2 (approx.)	Total height H3 (approx.)	Total length L1 (approx.)	Belt width B1 (approx.)	Hopper width B2 (approx.)	
BBR45	820-1050	820-960	1490-1630	1880	250	350	33°
BBR70	800-1050	850-1010	1480-1640	1890	250	680	33°
BBR150	820-1080	1040-1220	1500-1690	1930	250	920	33°
BBR250	740-980	1100-1230	1580-1710	2040	400	1030	33°
BBR350	730-1010	1200-1380	1560-1750	2070	400	1200	33°

*Dimensions may deviate from the table depending on the angle of attack A and the angular position of the chute

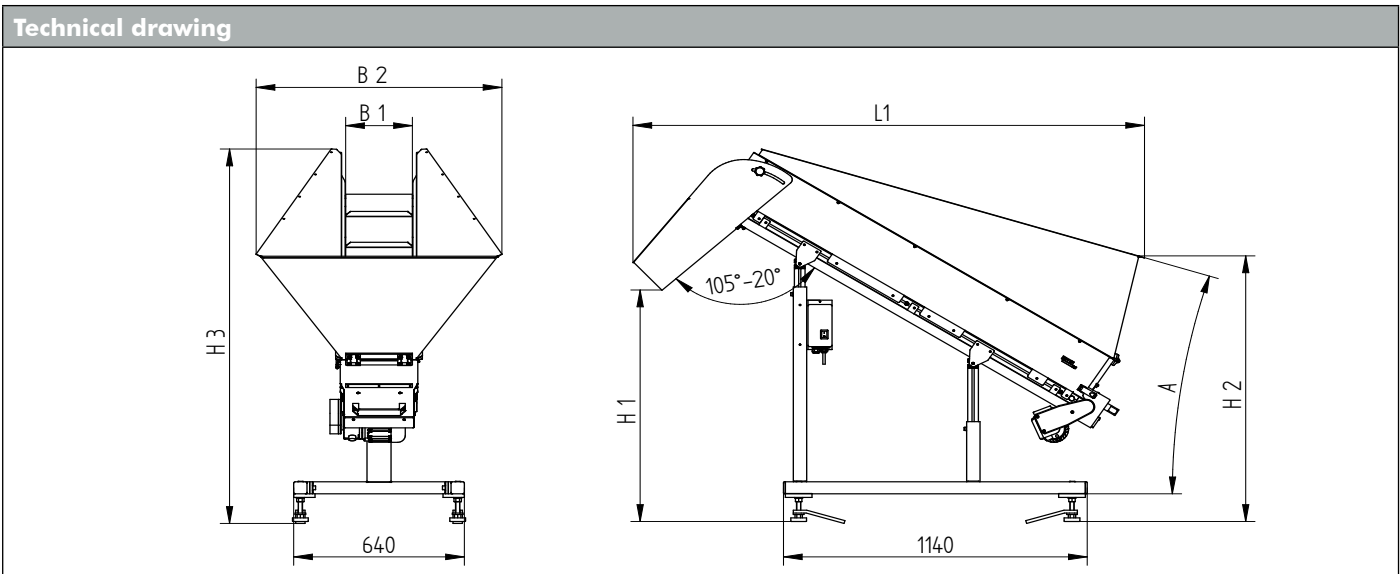

Accessories

Designation	Description	Article no.
Hopper control BS5	Hopper control BS5 for belt hopper of type BSF-1, BBH40-BBH80, BBR, BBV	21008720
Hopper control BS5V	Hopper control BS5V for belt hopper of type BSF-1, BBH40-BBH80, BBR, BBV	21012010
Pendulum switch PS1	Automated filling level control in the sorting device, inductive switch without wear	21005856
Filling level query	Filling level query in the bulk hopper with light barrier divided into two parts	10000268
Cover for BBR	Cover over the bulk hopper made of transparent acrylic glass	–
Rollable frame	Instead of the feet	–